



Schrumpffutter zum Spannen von HM Werkzeugschäften

Shrink chuck for mounting of solid carbide cutters

Mandrin de frettage pour le serrage des queue d'outils carbure

Isıtmalı takım tutucular şaftı karbür olan takımlar için

| | | | |
|-------------------------------|------------|---|--|
| JIS B 6339 (MAS 403 BT) | AD AD/B | HRC 52±2 | $\leq 3\mu\text{m}$ |
| h6 | | STANDARD G 2.5 25,000 min ⁻¹ U.S. system | SPECIAL max. G 2.5 50,000 min ⁻¹ U.S. system |
| | | | CHIP |

| Bestell-Nr. Order Nr. Reference Sipariş Nr. | BT | Form | d | A | D | D1 | L2 | Kg | Euro |
|--|-------|------|----|----|----|----|----|------|------|
| 305.25.03.80 | BT 30 | AD | 3 | 80 | 10 | 16 | 14 | 0,44 | |
| 305.25.04.80 | BT 30 | AD | 4 | 80 | 12 | 20 | 17 | 0,47 | |
| 305.25.05.80 | BT 30 | AD | 5 | 80 | 12 | 21 | 20 | 0,47 | |
| 305.25.06.80 | BT 30 | AD | 6 | 80 | 21 | 27 | 36 | 0,59 | |
| 305.25.08.80 | BT 30 | AD | 8 | 80 | 21 | 27 | 36 | 0,58 | |
| 305.25.10.80 | BT 30 | AD | 10 | 80 | 24 | 32 | 42 | 0,64 | |
| 305.25.12.80 | BT 30 | AD | 12 | 80 | 24 | 32 | 47 | 0,62 | |
| 305.25.14.80 | BT 30 | AD | 14 | 80 | 27 | 34 | 47 | 0,67 | |
| 305.25.16.80 | BT 30 | AD | 16 | 80 | 27 | 34 | 50 | 0,64 | |
| 305.25.18.80 | BT 30 | AD | 18 | 80 | 33 | 42 | 50 | 0,78 | |
| 305.25.20.80 | BT 30 | AD | 20 | 80 | 33 | 42 | 52 | 0,74 | |

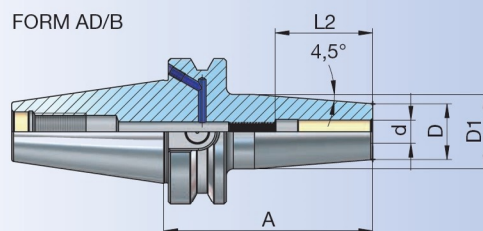
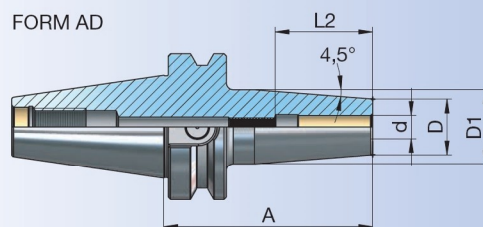

| | | | | | | | | | |
|---------------------------|-------|------|---|-----|----|------|----|------|--|
| 406.25.03.90 | BT 40 | AD/B | 3 | 90 | 10 | 16 | 14 | 1,05 | |
| *406.25.03.120 | BT 40 | AD/B | 3 | 120 | 10 | 16 | 14 | 1,06 | |
| *406.25.03.160 | BT 40 | AD/B | 3 | 160 | 10 | 16 | 14 | 1,11 | |
| new *406.25.03.200 | BT 40 | AD/B | 3 | 200 | 10 | 16 | 14 | 1,17 | |
| 406.25.04.90 | BT 40 | AD/B | 4 | 90 | 12 | 20 | 17 | 1,04 | |
| *406.25.04.120 | BT 40 | AD/B | 4 | 120 | 12 | 20 | 17 | 1,12 | |
| *406.25.04.160 | BT 40 | AD/B | 4 | 160 | 12 | 20 | 17 | 1,21 | |
| new *406.25.04.200 | BT 40 | AD/B | 4 | 200 | 12 | 20 | 17 | 1,30 | |
| 406.25.05.90 | BT 40 | AD/B | 5 | 90 | 12 | 21,5 | 20 | 1,04 | |
| *406.25.05.120 | BT 40 | AD/B | 5 | 120 | 12 | 22 | 20 | 1,13 | |
| *406.25.05.160 | BT 40 | AD/B | 5 | 160 | 12 | 22 | 20 | 1,24 | |
| new *406.25.05.200 | BT 40 | AD/B | 5 | 200 | 12 | 22 | 20 | 1,34 | |
| 406.25.06.90 | BT 40 | AD/B | 6 | 90 | 21 | 27 | 36 | 1,19 | |
| 406.25.06.120 | BT 40 | AD/B | 6 | 120 | 21 | 27 | 36 | 1,31 | |
| 406.25.06.160 | BT 40 | AD/B | 6 | 160 | 21 | 27 | 36 | 1,48 | |
| new *406.25.06.200 | BT 40 | AD/B | 6 | 200 | 21 | 27 | 36 | 1,64 | |
| 406.25.08.90 | BT 40 | AD/B | 8 | 90 | 21 | 27 | 36 | 1,19 | |
| 406.25.08.120 | BT 40 | AD/B | 8 | 120 | 21 | 27 | 36 | 1,31 | |
| 406.25.08.160 | BT 40 | AD/B | 8 | 160 | 21 | 27 | 36 | 1,47 | |
| new *406.25.08.200 | BT 40 | AD/B | 8 | 200 | 21 | 27 | 36 | 1,65 | |

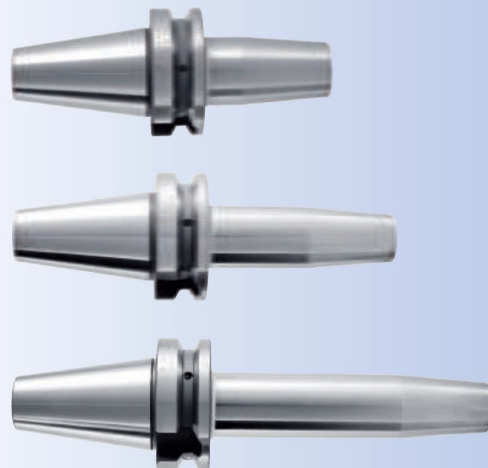

* Einstellschraube nicht enthalten
 * Does not include adjusting screw
 * Ne comprend pas la vis de réglage
 * Dayama civatası içermez



JIS B 6339
(MAS 403 BT)

Schrumpffutter zum Spannen von HM Werkzeugschäften

Shrink chuck for mounting of solid carbide cutters

Mandrin de frettage pour le serrage des queue d'outils carbure

Isıtılmalı takım tutucular şaftı karbür olan takımlar için

| | | | |
|----------------------------|---------------|--|---|
| JIS B 6339 (MAS 403 BT) | AD/B | HRC 52+2 | $f \leq 3\mu\text{m}$ |
| h6 | | STANDARD G 2.5 25,000 max U ≤ 1gmm | SPECIAL max. G 2.5 50,000 max U ≤ 1gmm |
| Option Type KKB | Option Type B | Option Type DB | CHIP |

| Bestell-Nr. Order Nr. Reference Sipariş Nr. | BT | Form | d | A | D | D1 | L2 | Kg | Euro |
|--|-------|------|----|-----|----|----|----|------|------|
| 406.25.10.90 | BT 40 | AD/B | 10 | 90 | 24 | 32 | 42 | 1,25 | |
| 406.25.10.120 | BT 40 | AD/B | 10 | 120 | 24 | 32 | 42 | 1,43 | |
| 406.25.10.160 | BT 40 | AD/B | 10 | 160 | 24 | 32 | 42 | 1,66 | |
| new 406.25.10.200 | BT 40 | AD/B | 10 | 200 | 24 | 32 | 42 | 1,90 | |
| 406.25.12.90 | BT 40 | AD/B | 12 | 90 | 24 | 32 | 47 | 1,22 | |
| 406.25.12.120 | BT 40 | AD/B | 12 | 120 | 24 | 32 | 47 | 1,38 | |
| 406.25.12.160 | BT 40 | AD/B | 12 | 160 | 24 | 32 | 47 | 1,60 | |
| new 406.25.12.200 | BT 40 | AD/B | 12 | 200 | 24 | 32 | 47 | 1,82 | |
| 406.25.14.90 | BT 40 | AD/B | 14 | 90 | 27 | 34 | 47 | 1,27 | |
| 406.25.14.120 | BT 40 | AD/B | 14 | 120 | 27 | 34 | 47 | 1,45 | |
| 406.25.14.160 | BT 40 | AD/B | 14 | 160 | 27 | 34 | 47 | 1,71 | |
| new 406.25.14.200 | BT 40 | AD/B | 14 | 200 | 27 | 34 | 47 | 1,95 | |
| 406.25.16.90 | BT 40 | AD/B | 16 | 90 | 27 | 34 | 50 | 1,25 | |
| 406.25.16.120 | BT 40 | AD/B | 16 | 120 | 27 | 34 | 50 | 1,43 | |
| 406.25.16.160 | BT 40 | AD/B | 16 | 160 | 27 | 34 | 50 | 1,69 | |
| new 406.25.16.200 | BT 40 | AD/B | 16 | 200 | 27 | 34 | 50 | 1,93 | |
| 406.25.18.90 | BT 40 | AD/B | 18 | 90 | 33 | 42 | 50 | 1,40 | |
| 406.25.18.120 | BT 40 | AD/B | 18 | 120 | 33 | 42 | 50 | 1,70 | |
| 406.25.18.160 | BT 40 | AD/B | 18 | 160 | 33 | 42 | 50 | 2,10 | |
| new 406.25.18.200 | BT 40 | AD/B | 18 | 200 | 33 | 42 | 50 | 2,50 | |
| 406.25.20.90 | BT 40 | AD/B | 20 | 90 | 33 | 42 | 52 | 1,37 | |
| 406.25.20.120 | BT 40 | AD/B | 20 | 120 | 33 | 42 | 52 | 1,67 | |
| 406.25.20.160 | BT 40 | AD/B | 20 | 160 | 33 | 42 | 52 | 2,07 | |
| new 406.25.20.200 | BT 40 | AD/B | 20 | 200 | 33 | 42 | 52 | 2,47 | |
| 406.25.25.90 | BT 40 | AD/B | 25 | 90 | 44 | 53 | 58 | 1,65 | |
| 406.25.25.120 | BT 40 | AD/B | 25 | 120 | 44 | 53 | 58 | 2,14 | |
| 406.25.25.160 | BT 40 | AD/B | 25 | 160 | 44 | 53 | 58 | 2,80 | |
| new 406.25.25.200 | BT 40 | AD/B | 25 | 200 | 44 | 53 | 58 | 3,45 | |
| 406.25.32.90 | BT 40 | AD/B | 32 | 90 | 44 | 53 | 62 | 1,49 | |
| 406.25.32.120 | BT 40 | AD/B | 32 | 120 | 44 | 53 | 62 | 1,98 | |
| 406.25.32.160 | BT 40 | AD/B | 32 | 160 | 44 | 53 | 62 | 2,63 | |
| new 406.25.32.200 | BT 40 | AD/B | 32 | 200 | 44 | 53 | 62 | 3,28 | |

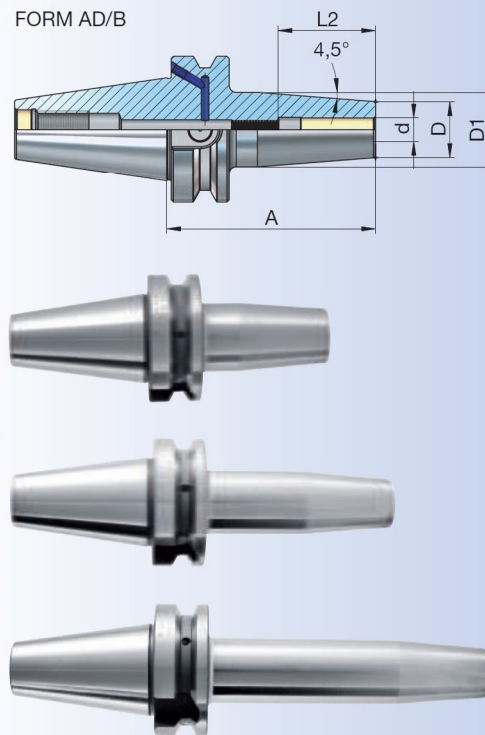



Schrumpffutter zum Spannen von HM Werkzeugschäften

Shrink chuck for mounting of solid carbide cutters

Mandrin de frettage pour le serrage des queue d'outils carbure

İsıtmalı takım tutucular şaftı karbür olan takımlar için

| | | | |
|-------------------------------|------------------|---|--|
| JIS B 6339 (MAS 403 BT) | AD/B | HRC 52±2 | $\lambda \leq 3\mu\text{m}$ |
| h6 | | STANDARD G 2.5 25,000 U ± 1gmm | SPECIAL max. G 2.5 50,000 U ± 1gmm |
| Option Type KKB | Option Type B | Option Type DB | CHIP |

| Bestell-Nr. Order Nr. Reference Sipariş Nr. | BT | Form | d | A | D | D1 | L2 | Kg | Euro |
|--|-------|------|----|-----|----|------|----|------|------|
| 506.25.03.100 | BT 50 | AD/B | 3 | 100 | 10 | 16 | 14 | 3,64 | |
| *506.25.03.120 | BT 50 | AD/B | 3 | 120 | 10 | 16 | 14 | 3,68 | |
| *506.25.03.160 | BT 50 | AD/B | 3 | 160 | 10 | 16 | 14 | 3,73 | |
| new *506.25.03.200 | BT 50 | AD/B | 3 | 200 | 10 | 16 | 14 | 3,79 | |
| 506.25.04.100 | BT 50 | AD/B | 4 | 100 | 12 | 20 | 17 | 3,68 | |
| *506.25.04.120 | BT 50 | AD/B | 4 | 120 | 12 | 20 | 17 | 3,73 | |
| *506.25.04.160 | BT 50 | AD/B | 4 | 160 | 12 | 20 | 17 | 3,82 | |
| new *506.25.04.200 | BT 50 | AD/B | 4 | 200 | 12 | 20 | 17 | 3,91 | |
| 506.25.05.100 | BT 50 | AD/B | 5 | 100 | 12 | 21,5 | 20 | 3,68 | |
| *506.25.05.120 | BT 50 | AD/B | 5 | 120 | 12 | 22 | 20 | 3,73 | |
| *506.25.05.160 | BT 50 | AD/B | 5 | 160 | 12 | 22 | 20 | 3,84 | |
| new *506.25.05.200 | BT 50 | AD/B | 5 | 200 | 12 | 22 | 20 | 3,95 | |
| 506.25.06.100 | BT 50 | AD/B | 6 | 100 | 21 | 27 | 36 | 3,84 | |
| 506.25.06.120 | BT 50 | AD/B | 6 | 120 | 21 | 27 | 36 | 3,92 | |
| 506.25.06.160 | BT 50 | AD/B | 6 | 160 | 21 | 27 | 36 | 4,08 | |
| new 506.25.06.200 | BT 50 | AD/B | 6 | 200 | 21 | 27 | 36 | 4,24 | |
| 506.25.08.100 | BT 50 | AD/B | 8 | 100 | 21 | 27 | 36 | 3,83 | |
| 506.25.08.120 | BT 50 | AD/B | 8 | 120 | 21 | 27 | 36 | 3,91 | |
| 506.25.08.160 | BT 50 | AD/B | 8 | 160 | 21 | 27 | 36 | 4,07 | |
| new 506.25.08.200 | BT 50 | AD/B | 8 | 200 | 21 | 27 | 36 | 4,23 | |
| 506.25.10.100 | BT 50 | AD/B | 10 | 100 | 24 | 32 | 42 | 3,86 | |
| 506.25.10.120 | BT 50 | AD/B | 10 | 120 | 24 | 32 | 42 | 4,01 | |
| 506.25.10.160 | BT 50 | AD/B | 10 | 160 | 24 | 32 | 42 | 4,25 | |
| new 506.25.10.200 | BT 50 | AD/B | 10 | 200 | 24 | 32 | 42 | 4,50 | |
| 506.25.12.100 | BT 50 | AD/B | 12 | 100 | 24 | 32 | 47 | 3,85 | |
| 506.25.12.120 | BT 50 | AD/B | 12 | 120 | 24 | 32 | 47 | 3,96 | |
| 506.25.12.160 | BT 50 | AD/B | 12 | 160 | 24 | 32 | 47 | 4,18 | |
| new 506.25.12.200 | BT 50 | AD/B | 12 | 200 | 24 | 32 | 47 | 4,39 | |

FORM AD/B

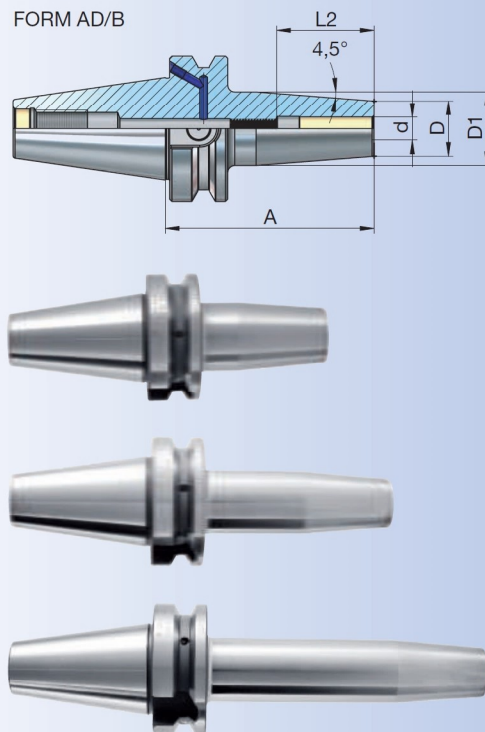

* Einstellschraube nicht enthalten
 * Does not include adjusting screw
 * Ne comprend pas la vis de réglage
 * Dayama civatasi içermez



Schrumpffutter zum Spannen von HM Werkzeugschäften



Shrink chuck for mounting of solid carbide cutters

Mandrin de frettage pour le serrage des queue d'outils carbure

Isıtımlı takım tutucular şaftı karbür olan takımlar için

| | | | |
|----------------------------|---------------|--|---|
| JIS B 6339 (MAS 403 BT) | AD/B | HRC 52±2 | $\sqrt{r} \leq 3\mu\text{m}$ |
| h6 | | STANDARD G 2,5 25.000 mm U ≤ 1mm | SPECIAL max. G 2,5 50.000 mm U ≤ 1mm |
| Option Type KKB | Option Type B | Option Type DB | CHIP |

JIS B 6339
(MAS 403 BT)

| Bestell-Nr. Order Nr. Reference Sipariş Nr. | BT | Form | d | A | D | D1 | L2 | Kg | Euro |
|--|-------|------|----|-----|----|----|----|------|------|
| 506.25.14.100 | BT 50 | AD/B | 14 | 100 | 27 | 34 | 47 | 3,90 | |
| 506.25.14.120 | BT 50 | AD/B | 14 | 120 | 27 | 34 | 47 | 4,02 | |
| 506.25.14.160 | BT 50 | AD/B | 14 | 160 | 27 | 34 | 47 | 4,27 | |
| new 506.25.14.200 | BT 50 | AD/B | 14 | 200 | 27 | 34 | 47 | 4,52 | |
| 506.25.16.100 | BT 50 | AD/B | 16 | 100 | 27 | 34 | 50 | 3,88 | |
| 506.25.16.120 | BT 50 | AD/B | 16 | 120 | 27 | 34 | 50 | 4,00 | |
| 506.25.16.160 | BT 50 | AD/B | 16 | 160 | 27 | 34 | 50 | 4,25 | |
| new 506.25.16.200 | BT 50 | AD/B | 16 | 200 | 27 | 34 | 50 | 4,50 | |
| 506.25.18.100 | BT 50 | AD/B | 18 | 100 | 33 | 42 | 50 | 4,03 | |
| 506.25.18.120 | BT 50 | AD/B | 18 | 120 | 33 | 42 | 50 | 4,22 | |
| 506.25.18.160 | BT 50 | AD/B | 18 | 160 | 33 | 42 | 50 | 4,63 | |
| new 506.25.18.200 | BT 50 | AD/B | 18 | 200 | 33 | 42 | 50 | 5,04 | |
| 506.25.20.100 | BT 50 | AD/B | 20 | 100 | 33 | 42 | 52 | 4,00 | |
| 506.25.20.120 | BT 50 | AD/B | 20 | 120 | 33 | 42 | 52 | 4,20 | |
| 506.25.20.160 | BT 50 | AD/B | 20 | 160 | 33 | 42 | 52 | 4,60 | |
| new 506.25.20.200 | BT 50 | AD/B | 20 | 200 | 33 | 42 | 52 | 5,03 | |
| 506.25.25.110 | BT 50 | AD/B | 25 | 110 | 44 | 53 | 58 | 4,44 | |
| 506.25.25.120 | BT 50 | AD/B | 25 | 120 | 44 | 53 | 58 | 4,60 | |
| 506.25.25.160 | BT 50 | AD/B | 25 | 160 | 44 | 53 | 58 | 5,25 | |
| new 506.25.25.200 | BT 50 | AD/B | 25 | 200 | 44 | 53 | 58 | 5,91 | |
| 506.25.32.110 | BT 50 | AD/B | 32 | 110 | 44 | 53 | 62 | 4,27 | |
| 506.25.32.120 | BT 50 | AD/B | 32 | 120 | 44 | 53 | 62 | 4,43 | |
| 506.25.32.160 | BT 50 | AD/B | 32 | 160 | 44 | 53 | 62 | 5,09 | |
| new 506.25.32.200 | BT 50 | AD/B | 32 | 200 | 44 | 53 | 62 | 5,75 | |

FORM AD/B

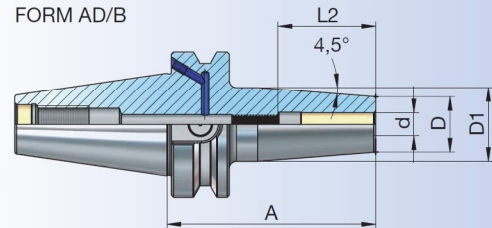

Schrumpffutter - schlanke Ausführung für HM Werkzeugschäften

Shrink chucks - slimline design for solid carbide cutters

Mandrins de frettage - design mince four queue d'outils carbure

İnce cidarlı ısıtılmalı takım tutucular şaftı karbür olan takımlar için

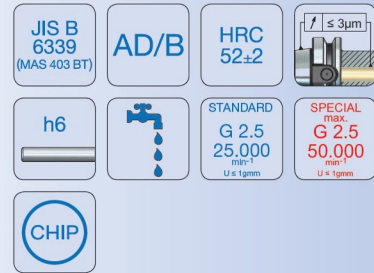

| Bestell-Nr. Order Nr. Reference Sipariş Nr. | BT | Form | d | A | D | D1 | L2 | Kg | Euro |
|--|-------|------|----|-----|----|------|----|------|------|
| 406.25.03.90.S | BT 40 | AD/B | 3 | 90 | 9 | 15 | 14 | 1,00 | |
| *406.25.03.120.S | BT 40 | AD/B | 3 | 120 | 9 | 18 | 14 | 1,04 | |
| 406.25.04.90.S | BT 40 | AD/B | 4 | 90 | 10 | 16 | 17 | 1,00 | |
| *406.25.04.120.S | BT 40 | AD/B | 4 | 120 | 10 | 19 | 17 | 1,06 | |
| 406.25.05.90.S | BT 40 | AD/B | 5 | 90 | 11 | 17 | 20 | 1,01 | |
| *406.25.05.120.S | BT 40 | AD/B | 5 | 120 | 11 | 20 | 20 | 1,07 | |
| 406.25.06.90.S | BT 40 | AD/B | 6 | 90 | 12 | 18 | 36 | 1,04 | |
| 406.25.06.120.S | BT 40 | AD/B | 6 | 120 | 12 | 21 | 36 | 1,10 | |
| 406.25.06.160.S | BT 40 | AD/B | 6 | 160 | 12 | 25 | 36 | 1,22 | |
| 406.25.08.90.S | BT 40 | AD/B | 8 | 90 | 14 | 20 | 36 | 1,06 | |
| 406.25.08.120.S | BT 40 | AD/B | 8 | 120 | 14 | 23 | 36 | 1,14 | |
| 406.25.08.160.S | BT 40 | AD/B | 8 | 160 | 14 | 27 | 36 | 1,28 | |
| 406.25.10.90.S | BT 40 | AD/B | 10 | 90 | 16 | 22 | 42 | 1,08 | |
| 406.25.10.120.S | BT 40 | AD/B | 10 | 120 | 16 | 25 | 42 | 1,17 | |
| 406.25.10.160.S | BT 40 | AD/B | 10 | 160 | 16 | 29 | 42 | 1,34 | |
| 406.25.12.90.S | BT 40 | AD/B | 12 | 90 | 18 | 24 | 47 | 1,08 | |
| 406.25.12.120.S | BT 40 | AD/B | 12 | 120 | 18 | 27 | 47 | 1,17 | |
| 406.25.12.160.S | BT 40 | AD/B | 12 | 160 | 18 | 31 | 47 | 1,36 | |
| | | | | | | | | | |
| 506.25.03.100.S | BT 50 | AD/B | 3 | 100 | 9 | 15 | 14 | 3,63 | |
| *506.25.03.120.S | BT 50 | AD/B | 3 | 120 | 9 | 17,5 | 14 | 3,66 | |
| 506.25.04.100.S | BT 50 | AD/B | 4 | 100 | 10 | 16 | 17 | 3,64 | |
| *506.25.04.120.S | BT 50 | AD/B | 4 | 120 | 10 | 18,5 | 17 | 3,67 | |
| 506.25.05.100.S | BT 50 | AD/B | 5 | 100 | 11 | 17 | 20 | 3,65 | |
| *506.25.05.120.S | BT 50 | AD/B | 5 | 120 | 11 | 19,5 | 20 | 3,68 | |
| 506.25.06.100.S | BT 50 | AD/B | 6 | 100 | 12 | 18 | 36 | 3,69 | |
| 506.25.06.120.S | BT 50 | AD/B | 6 | 120 | 12 | 20,5 | 36 | 3,72 | |
| 506.25.06.160.S | BT 50 | AD/B | 6 | 160 | 12 | 24,5 | 36 | 3,83 | |
| 506.25.08.100.S | BT 50 | AD/B | 8 | 100 | 14 | 20 | 36 | 3,70 | |
| 506.25.08.120.S | BT 50 | AD/B | 8 | 120 | 14 | 22,5 | 36 | 3,75 | |
| 506.25.08.160.S | BT 50 | AD/B | 8 | 160 | 14 | 26,5 | 36 | 3,88 | |
| 506.25.10.100.S | BT 50 | AD/B | 10 | 100 | 16 | 22 | 42 | 3,72 | |
| 506.25.10.120.S | BT 50 | AD/B | 10 | 120 | 16 | 24,5 | 42 | 3,78 | |
| 506.25.10.160.S | BT 50 | AD/B | 10 | 160 | 16 | 28,5 | 42 | 3,94 | |
| 506.25.12.100.S | BT 50 | AD/B | 12 | 100 | 18 | 24 | 47 | 3,71 | |
| 506.25.12.120.S | BT 50 | AD/B | 12 | 120 | 18 | 26,5 | 47 | 3,77 | |
| 506.25.12.160.S | BT 50 | AD/B | 12 | 160 | 18 | 30,5 | 47 | 3,94 | |

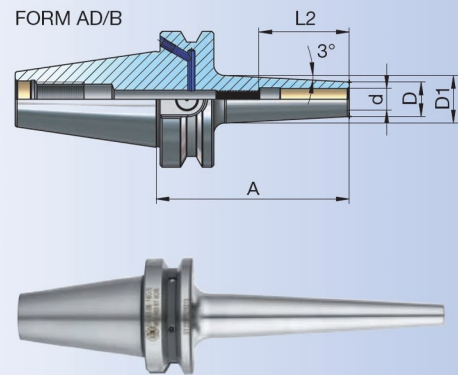

* Einstellschraube nicht enthalten
 * Does not include adjusting screw
 * Ne comprend pas la vis de réglage
 * Dayama civatası içermez