

Schrumpffutter zum Spannen von HM Werkzeugschäften

HSK-A



Shrink chuck for mounting of solid carbide cutters

Mandrin de frettage pour le serrage des queue d'outils carbure

Isıtmalı takım tutucular şaftı karbür olan takımlar için

DIN 69893-1 FORM A	DIN 69882-8	HRC 52±2	$\leq 3\mu\text{m}$
h6		STANDARD G 2.5 25,000 min ⁻¹ U ≤ 1g/mm	SPECIAL max. G 2.5 50,000 min ⁻¹ U ≤ 1g/mm
Option Type KKB	Option Type B	Option Type DB	CHIP

Bestell-Nr. Order Nr. Reference Sipariş Nr.	HSK	d	A	D	D1	L2	Kg	Euro
A32.25.03.60	HSK-A 32	3	60	10	16	14	0,16	
A32.25.04.60	HSK-A 32	4	60	12	18	17	0,17	
A32.25.05.60	HSK-A 32	5	60	12	18	20	0,17	
A32.25.06.70	HSK-A 32	6	70	21	26	36	0,28	
A32.25.08.70	HSK-A 32	8	70	21	26	36	0,28	
A32.25.10.70	HSK-A 32	10	70	24	29	42	0,30	
A32.25.12.80	HSK-A 32	12	80	24	29	47	0,33	
A40.25.03.60	HSK-A 40	3	60	10	16	14	0,23	
*A40.25.03.120	HSK-A 40	3	120	10	16	14	0,32	
*A40.25.03.160	HSK-A 40	3	160	10	16	14	0,37	
A40.25.04.60	HSK-A 40	4	60	12	18	17	0,25	
*A40.25.04.120	HSK-A 40	4	120	12	20	17	0,38	
*A40.25.04.160	HSK-A 40	4	160	12	20	17	0,47	
A40.25.05.60	HSK-A 40	5	60	12	18	20	0,25	
*A40.25.05.120	HSK-A 40	5	120	12	22	20	0,40	
*A40.25.05.160	HSK-A 40	5	160	12	22	20	0,51	
A40.25.06.80	HSK-A 40	6	80	21	27	36	0,41	
A40.25.06.120	HSK-A 40	6	120	21	27	36	0,59	
A40.25.06.160	HSK-A 40	6	160	21	27	36	0,76	
A40.25.08.80	HSK-A 40	8	80	21	27	36	0,41	
A40.25.08.120	HSK-A 40	8	120	21	27	36	0,58	
A40.25.08.160	HSK-A 40	8	160	21	27	36	0,75	
A40.25.10.80	HSK-A 40	10	80	24	32	42	0,47	
A40.25.10.120	HSK-A 40	10	120	24	32	42	0,71	
A40.25.10.160	HSK-A 40	10	160	24	32	42	0,95	
A40.25.12.90	HSK-A 40	12	90	24	32	47	0,51	
A40.25.12.120	HSK-A 40	12	120	24	32	47	0,69	
A40.25.12.160	HSK-A 40	12	160	24	32	47	0,94	
A40.25.14.90	HSK-A 40	14	90	27	34	47	0,55	
A40.25.14.120	HSK-A 40	14	120	27	34	47	0,76	
A40.25.14.160	HSK-A 40	14	160	27	34	47	1,04	
A40.25.16.90	HSK-A 40	16	90	27	34	50	0,53	
A40.25.16.120	HSK-A 40	16	120	27	34	50	0,74	
A40.25.16.160	HSK-A 40	16	160	27	34	50	1,01	

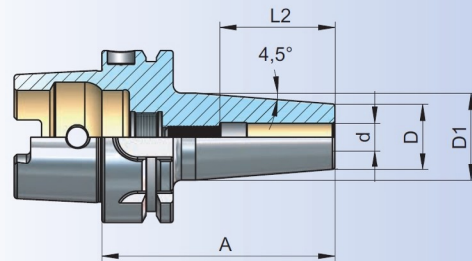

- * Einstellschraube nicht enthalten
- * Does not include adjusting screw
- * Ne comprend pas la vis de réglage
- * Dayama civatası içermez



Schrumpffutter zum Spannen von HM Werkzeugschäften

HSK-A

Shrink chuck for mounting of solid carbide cutters

Mandrin de frettage pour le serrage des queue d'outils carbure

Isıtmalı takım tutucular şaftı karbür olan takımlar için

DIN 69893-1 FORM A	DIN 69882-8	HRC 52±2	$f \leq 3\mu\text{m}$
h6		STANDARD G 2.5 25,000 mm ³ U ≤ 1gmm	SPECIAL max. G 2.5 50,000 mm ³ U ≤ 1gmm
Option Type KKB	Option Type B	Option Type DB	CHIP

Bestell-Nr. Order Nr. Reference Sipariş Nr.	HSK	d	A	D	D1	L2	Kg	Euro
A50.25.03.80	HSK-A 50	3	80	10	16	14	0,44	
*A50.25.03.120	HSK-A 50	3	120	10	16	14	0,50	
*A50.25.03.160	HSK-A 50	3	160	10	16	14	0,56	
A50.25.04.80	HSK-A 50	4	80	12	20	17	0,47	
*A50.25.04.120	HSK-A 50	4	120	12	20	17	0,56	
*A50.25.04.160	HSK-A 50	4	160	12	20	17	0,65	
A50.25.05.80	HSK-A 50	5	80	12	20,5	20	0,46	
*A50.25.05.120	HSK-A 50	5	120	12	22	20	0,57	
*A50.25.05.160	HSK-A 50	5	160	12	22	20	0,68	
A50.25.06.80	HSK-A 50	6	80	21	27	36	0,58	
A50.25.06.120	HSK-A 50	6	120	21	27	36	0,75	
A50.25.06.160	HSK-A 50	6	160	21	27	36	0,92	
A50.25.08.80	HSK-A 50	8	80	21	27	36	0,58	
A50.25.08.120	HSK-A 50	8	120	21	27	36	0,74	
A50.25.08.160	HSK-A 50	8	160	21	27	36	0,91	
A50.25.10.85	HSK-A 50	10	85	24	32	42	0,65	
A50.25.10.120	HSK-A 50	10	120	24	32	42	0,86	
A50.25.10.160	HSK-A 50	10	160	24	32	42	1,11	
A50.25.12.90	HSK-A 50	12	90	24	32	47	0,67	
A50.25.12.120	HSK-A 50	12	120	24	32	47	0,85	
A50.25.12.160	HSK-A 50	12	160	24	32	47	1,09	
A50.25.14.90	HSK-A 50	14	90	27	34	47	0,72	
A50.25.14.120	HSK-A 50	14	120	27	34	47	0,92	
A50.25.14.160	HSK-A 50	14	160	27	34	47	1,19	
A50.25.16.95	HSK-A 50	16	95	27	34	50	0,73	
A50.25.16.120	HSK-A 50	16	120	27	34	50	0,90	
A50.25.16.160	HSK-A 50	16	160	27	34	50	1,17	
A50.25.18.95	HSK-A 50	18	95	33	42	50	0,90	
A50.25.18.120	HSK-A 50	18	120	33	42	50	1,16	
A50.25.18.160	HSK-A 50	18	160	33	42	50	1,58	
A50.25.20.100	HSK-A 50	20	100	33	42	52	0,94	
A50.25.20.120	HSK-A 50	20	120	33	42	52	1,13	
A50.25.20.160	HSK-A 50	20	160	33	42	52	1,55	

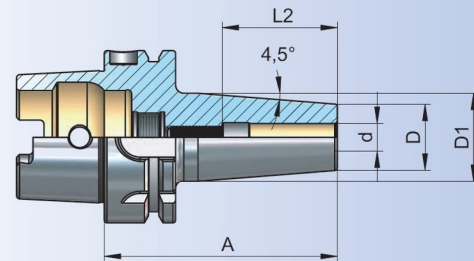

- * Einstellschraube nicht enthalten
- * Does not include adjusting screw
- * Ne comprend pas la vis de réglage
- * Dayama civatasi içermez

Schrumpffutter zum Spannen von HM Werkzeugschäften

HSK-A



Shrink chuck for mounting of solid carbide cutters

Mandrin de frettage pour le serrage des queue d'outils carbure

Isıtmalı takım tutucular şaftı karbür olan takımlar için

DIN 69893-1 FORM A	DIN 69882-8	HRC 52±2	$f \leq 3\mu\text{m}$
h6		STANDARD G 2.5 25,000 min ⁻¹ U ≤ 1gmm	SPECIAL max. G 2.5 50,000 min ⁻¹ U ≤ 1gmm
Option Type KKB	Option Type B	Option Type DB	CHIP

Bestell-Nr. Order Nr. Reference Sipariş Nr.	HSK	d	A	D	D1	L2	Kg	Euro
A63.25.03.80	HSK-A 63	3	80	10	16	14	0,70	
*A63.25.03.120	HSK-A 63	3	120	10	16	14	0,75	
*A63.25.03.160	HSK-A 63	3	160	10	16	14	0,81	
A63.25.04.80	HSK-A 63	4	80	12	20	17	0,72	
*A63.25.04.120	HSK-A 63	4	120	12	20	17	0,81	
*A63.25.04.160	HSK-A 63	4	160	12	20	17	0,91	
A63.25.05.80	HSK-A 63	5	80	12	20,5	20	0,72	
*A63.25.05.120	HSK-A 63	5	120	12	22	20	0,83	
*A63.25.05.160	HSK-A 63	5	160	12	22	20	0,90	
A63.25.06.80	HSK-A 63	6	80	21	27	36	0,84	
A63.25.06.120	HSK-A 63	6	120	21	27	36	1,00	
A63.25.06.160	HSK-A 63	6	160	21	27	36	1,16	
A63.25.06.200	HSK-A 63	6	200	21	27	36	1,33	
A63.25.08.80	HSK-A 63	8	80	21	27	36	0,83	
A63.25.08.120	HSK-A 63	8	120	21	27	36	0,99	
A63.25.08.160	HSK-A 63	8	160	21	27	36	1,15	
A63.25.08.200	HSK-A 63	8	200	21	27	36	1,33	
A63.25.10.85	HSK-A 63	10	85	24	32	42	0,91	
A63.25.10.120	HSK-A 63	10	120	24	32	42	1,11	
A63.25.10.160	HSK-A 63	10	160	24	32	42	1,35	
A63.25.10.200	HSK-A 63	10	200	24	32	42	1,59	
A63.25.12.90	HSK-A 63	12	90	24	32	47	0,92	
A63.25.12.120	HSK-A 63	12	120	24	32	47	1,10	
A63.25.12.160	HSK-A 63	12	160	24	32	47	1,33	
A63.25.12.200	HSK-A 63	12	200	24	32	47	1,57	

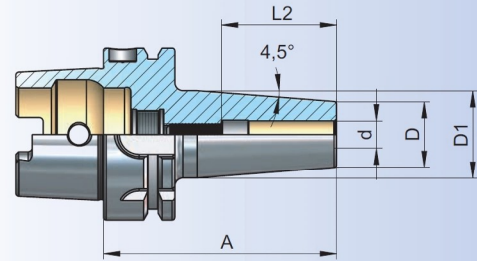



Schrumpffutter zum Spannen von HM Werkzeugschäften

HSK-A

Shrink chuck for mounting of solid carbide cutters

Mandrin de frettage pour le serrage des queue d'outils carbure

Isıtımalı takım tutucular şaftı karbür olan takımlar için

DIN 69893-1 FORM A	DIN 69882-8	HRC 52±2	$\leq 3\mu\text{m}$
h6		STANDARD G 2.5 25.000 max. 1 U ≤ 19mm	SPECIAL max. 2.5 50.000 max. 1 U ≤ 19mm
Option Type KKB	Option Type B	Option Type DB	CHIP

Bestell-Nr. Order Nr. Reference Sipariş Nr.	HSK	d	A	D	D1	L2	Kg	Euro
A63.25.14.90	HSK-A 63	14	90	27	34	47	0,97	
A63.25.14.120	HSK-A 63	14	120	27	34	47	1,17	
A63.25.14.160	HSK-A 63	14	160	27	34	47	1,44	
A63.25.14.200	HSK-A 63	14	200	27	34	47	1,71	
A63.25.16.95	HSK-A 63	16	95	27	34	50	0,98	
A63.25.16.120	HSK-A 63	16	120	27	34	50	1,15	
A63.25.16.160	HSK-A 63	16	160	27	34	50	1,42	
A63.25.16.200	HSK-A 63	16	200	27	34	50	1,69	
A63.25.18.95	HSK-A 63	18	95	33	42	50	1,16	
A63.25.18.120	HSK-A 63	18	120	33	42	50	1,42	
A63.25.18.160	HSK-A 63	18	160	33	42	50	1,83	
A63.25.18.200	HSK-A 63	18	200	33	42	50	2,25	
A63.25.20.100	HSK-A 63	20	100	33	42	52	1,20	
A63.25.20.120	HSK-A 63	20	120	33	42	52	1,38	
A63.25.20.160	HSK-A 63	20	160	33	42	52	1,80	
A63.25.20.200	HSK-A 63	20	200	33	42	52	2,22	
A63.25.25.115	HSK-A 63	25	115	44	53	58	1,77	
A63.25.25.120	HSK-A 63	25	120	44	53	58	1,85	
A63.25.25.160	HSK-A 63	25	160	44	53	58	2,52	
A63.25.25.200	HSK-A 63	25	200	44	53	58	3,19	
A63.25.32.120	HSK-A 63	32	120	44	53	62	1,69	
A63.25.32.160	HSK-A 63	32	160	44	53	62	2,36	
A63.25.32.200	HSK-A 63	32	200	44	53	62	3,03	

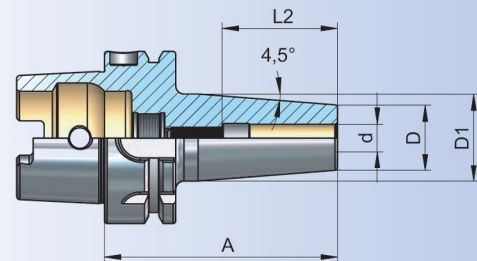

Schrumpffutter zum Spannen von HM Werkzeugschäften

HSK-A



Shrink chuck for mounting of solid carbide cutters

Mandrin de frettage pour le serrage des queue d'outils carbure

Isıtmalı takım tutucular şaftı karbür olan takımlar için

DIN 69893-1 FORM A	DIN 69882-8	HRC 52±2	$f \leq 3\mu\text{m}$
h6		STANDARD G 2.5 25,000 mit U ≤ 1mm	SPECIAL max. G 2.5 50,000 mit U ≤ 1mm
Option Type KKB	Option Type B	Option Type DB	CHIP

Bestell-Nr. Order Nr. Reference Sipariş Nr.	HSK	d	A	D	D1	L2	Kg	Euro
A80.25.06.85	HSK-A 80	6	85	21	27	36	1,30	
A80.25.06.120	HSK-A 80	6	120	21	27	36	1,44	
A80.25.06.160	HSK-A 80	6	160	21	27	36	1,60	
A80.25.08.85	HSK-A 80	8	85	21	27	36	1,29	
A80.25.08.120	HSK-A 80	8	120	21	27	36	1,43	
A80.25.08.160	HSK-A 80	8	160	21	27	36	1,59	
A80.25.10.90	HSK-A 80	10	90	24	32	42	1,38	
A80.25.10.120	HSK-A 80	10	120	24	32	42	1,55	
A80.25.10.160	HSK-A 80	10	160	24	32	42	1,79	
A80.25.12.95	HSK-A 80	12	95	24	32	47	1,39	
A80.25.12.120	HSK-A 80	12	120	24	32	47	1,53	
A80.25.12.160	HSK-A 80	12	160	24	32	47	1,76	
A80.25.14.95	HSK-A 80	14	95	27	34	47	1,44	
A80.25.14.120	HSK-A 80	14	120	27	34	47	1,60	
A80.25.14.160	HSK-A 80	14	160	27	34	47	1,86	
A80.25.16.100	HSK-A 80	16	100	27	34	50	1,46	
A80.25.16.120	HSK-A 80	16	120	27	34	50	1,59	
A80.25.16.160	HSK-A 80	16	160	27	34	50	1,85	
A80.25.18.100	HSK-A 80	18	100	33	42	50	1,65	
A80.25.18.120	HSK-A 80	18	120	33	42	50	1,85	
A80.25.18.160	HSK-A 80	18	160	33	42	50	2,27	
A80.25.20.105	HSK-A 80	20	105	33	42	52	1,68	
A80.25.20.120	HSK-A 80	20	120	33	42	52	1,82	
A80.25.20.160	HSK-A 80	20	160	33	42	52	2,23	
A80.25.25.115	HSK-A 80	25	115	44	53	58	2,23	
A80.25.25.120	HSK-A 80	25	120	44	53	58	2,30	
A80.25.25.160	HSK-A 80	25	160	44	53	58	2,97	
A80.25.32.120	HSK-A 80	32	120	44	53	62	2,13	
A80.25.32.160	HSK-A 80	32	160	44	53	62	2,80	

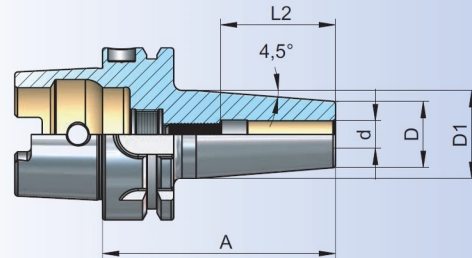



Schrumpffutter zum Spannen von HM Werkzeugschäften

HSK-A

Shrink chuck for mounting of solid carbide cutters

Mandrin de frettage pour le serrage des queue d'outils carbure

Isıtmalı takım tutucular şaftı karbür olan takımlar için

DIN 69893-1 FORM A	DIN 69882-8	HRC 52±2	$\sqrt{R} \leq 3\mu\text{m}$
h6		STANDARD G 2.5 25.000 mm ² U ≤ 1gmm	SPECIAL max. G 2.5 50.000 mm ² U ≤ 1gmm
Option Type KKB	Option Type B	Option Type DB	CHIP

Bestell-Nr. Order Nr. Reference Sipariş Nr.	HSK	d	A	D	D1	L2	Kg	Euro
A100.25.06.85	HSK-A 100	6	85	21	27	36	2,20	
A100.25.06.120	HSK-A 100	6	120	21	27	36	2,35	
A100.25.06.160	HSK-A 100	6	160	21	27	36	2,53	
A100.25.06.200	HSK-A 100	6	200	21	27	36	2,69	
A100.25.08.85	HSK-A 100	8	85	21	27	36	2,20	
A100.25.08.120	HSK-A 100	8	120	21	27	36	2,34	
A100.25.08.160	HSK-A 100	8	160	21	27	36	2,52	
A100.25.08.200	HSK-A 100	8	200	21	27	36	2,68	
A100.25.10.90	HSK-A 100	10	90	24	32	42	2,27	
A100.25.10.120	HSK-A 100	10	120	24	32	42	2,44	
A100.25.10.160	HSK-A 100	10	160	24	32	42	2,72	
A100.25.10.200	HSK-A 100	10	200	24	32	42	2,95	
A100.25.12.95	HSK-A 100	12	95	24	32	47	2,28	
A100.25.12.120	HSK-A 100	12	120	24	32	47	2,42	
A100.25.12.160	HSK-A 100	12	160	24	32	47	2,67	
A100.25.12.200	HSK-A 100	12	200	24	32	47	2,89	
A100.25.14.95	HSK-A 100	14	95	27	34	47	2,33	
A100.25.14.120	HSK-A 100	14	120	27	34	47	2,49	
A100.25.14.160	HSK-A 100	14	160	27	34	47	2,75	
A100.25.14.200	HSK-A 100	14	200	27	34	47	3,03	
A100.25.16.100	HSK-A 100	16	100	27	34	50	2,34	
A100.25.16.120	HSK-A 100	16	120	27	34	50	2,47	
A100.25.16.160	HSK-A 100	16	160	27	34	50	2,73	
A100.25.16.200	HSK-A 100	16	200	27	34	50	3,01	
A100.25.18.100	HSK-A 100	18	100	33	42	50	2,52	
A100.25.18.120	HSK-A 100	18	120	33	42	50	2,72	
A100.25.18.160	HSK-A 100	18	160	33	42	50	3,12	
A100.25.18.200	HSK-A 100	18	200	33	42	50	3,54	
A100.25.20.105	HSK-A 100	20	105	33	42	52	2,56	
A100.25.20.120	HSK-A 100	20	120	33	42	52	2,69	
A100.25.20.160	HSK-A 100	20	160	33	42	52	3,09	
A100.25.20.200	HSK-A 100	20	200	33	42	52	3,51	
A100.25.25.115	HSK-A 100	25	115	44	53	58	3,09	
A100.25.25.120	HSK-A 100	25	120	44	53	58	3,15	
A100.25.25.160	HSK-A 100	25	160	44	53	58	3,81	
A100.25.25.200	HSK-A 100	25	200	44	53	58	4,49	
A100.25.32.120	HSK-A 100	32	120	44	53	62	2,99	
A100.25.32.160	HSK-A 100	32	160	44	53	62	3,65	
A100.25.32.200	HSK-A 100	32	200	44	53	62	4,32	

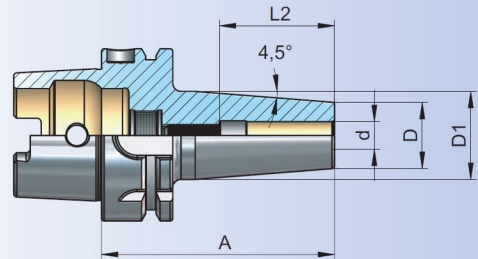

Schrumpffutter - schlanke Ausführung für HM Werkzeugschäften

HSK-A



Shrink chucks - slimline design for solid carbide cutters

Mandrins de frettage - design mince four queue d'outils carbure

İnce cidarlı ısıtılmalı takım tutucular şaftı karbür olan takımlar için

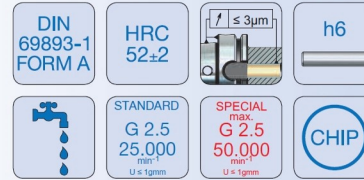

Bestell-Nr. Order Nr. Reference Sipariş Nr.	HSK	d	A	D	D1	L2	Kg	Euro
A63.25.03.80.S	HSK-A 63	3	80	9	14	14	0,68	
A63.25.03.120.S	HSK-A 63	3	120	9	18	14	0,74	
A63.25.04.80.S	HSK-A 63	4	80	10	15	17	0,69	
*A63.25.04.120.S	HSK-A 63	4	120	10	19	17	0,76	
*A63.25.04.160.S	HSK-A 63	4	160	10	23	17	0,87	
A63.25.05.80.S	HSK-A 63	5	80	11	16	20	0,69	
*A63.25.05.120.S	HSK-A 63	5	120	11	20	20	0,77	
*A63.25.05.160.S	HSK-A 63	5	160	11	24	20	0,89	
A63.25.06.80.S	HSK-A 63	6	80	12	17	36	0,71	
A63.25.06.120.S	HSK-A 63	6	120	12	21	36	0,78	
A63.25.06.160.S	HSK-A 63	6	160	12	25	36	0,91	
A63.25.08.80.S	HSK-A 63	8	80	14	19	36	0,72	
A63.25.08.120.S	HSK-A 63	8	120	14	23	36	0,82	
A63.25.08.160.S	HSK-A 63	8	160	14	27	36	0,96	
A63.25.10.85.S	HSK-A 63	10	85	16	21,5	42	0,75	
A63.25.10.120.S	HSK-A 63	10	120	16	25	42	0,85	
A63.25.10.160.S	HSK-A 63	10	160	16	29	42	1,03	
A63.25.12.90.S	HSK-A 63	12	90	18	24	47	0,78	
A63.25.12.120.S	HSK-A 63	12	120	18	27	47	0,89	
A63.25.12.160.S	HSK-A 63	12	160	18	31	47	1,09	

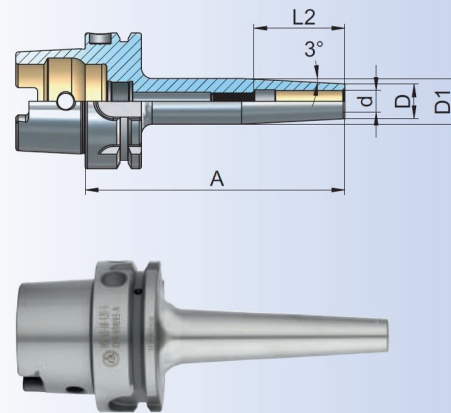

A100.25.06.85.S	HSK-A 100	6	85	12	17	36	2,09	
A100.25.06.120.S	HSK-A 100	6	120	12	20,5	36	2,18	
A100.25.06.160.S	HSK-A 100	6	160	12	25	36	2,27	
A100.25.06.200.S	HSK-A 100	6	200	12	29	36	2,47	
A100.25.08.85.S	HSK-A 100	8	85	14	19	36	2,11	
A100.25.08.120.S	HSK-A 100	8	120	14	22,5	36	2,22	
A100.25.08.160.S	HSK-A 100	8	160	14	27	36	2,33	
A100.25.08.200.S	HSK-A 100	8	200	14	31	36	2,56	
A100.25.10.90.S	HSK-A 100	10	90	16	21,5	42	2,12	
A100.25.10.120.S	HSK-A 100	10	120	16	24,5	42	2,22	
A100.25.10.160.S	HSK-A 100	10	160	16	29	42	2,37	
A100.25.10.200.S	HSK-A 100	10	200	16	33	42	2,62	
A100.25.12.95.S	HSK-A 100	12	95	18	24	47	2,15	
A100.25.12.120.S	HSK-A 100	12	120	18	26,5	47	2,25	
A100.25.12.160.S	HSK-A 100	12	160	18	31	47	2,41	
A100.25.12.200.S	HSK-A 100	12	200	18	35	47	2,67	
A100.25.16.100.S	HSK-A 100	16	100	22	29	50	2,19	
A100.25.16.120.S	HSK-A 100	16	120	22	31	50	2,29	
A100.25.16.160.S	HSK-A 100	16	160	22	35	50	2,55	
A100.25.16.200.S	HSK-A 100	16	200	22	39	50	2,88	

- * Einstellschraube nicht enthalten
- * Does not include adjusting screw
- * Ne comprend pas la vis de réglage
- * Dayama civatası içermez

Zubehör / Accessories / Accessoires / Yedekler



Einstellschraube
Adjusting screw
Vis de réglage
Dayama civatası



Schlüssel für
Kühlmittelübergabeeinheit
Wrench delivery unit
Clé pour raccord d'arrosage
Soğutma suyu ünitesi anahtarı